

How Aluminum is Recycled

2 The aluminum cans are transported to a processing facility where they use a big magnet to remove other types of metal cans while they go down the conveyor belt.

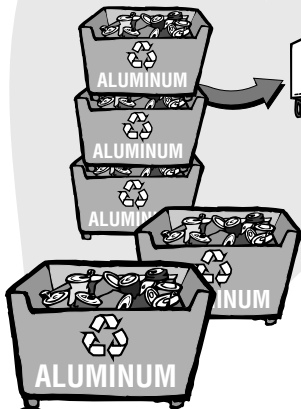

3 The aluminum is washed, shredded and turned into aluminum chips.

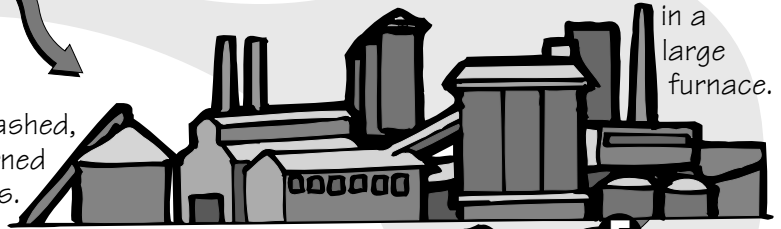

4 The aluminum chips are melted in a large furnace.

1 You can take your aluminum cans to a recycling center or leave them in recycling bins at your curb (if you have curbside service).

5 The liquid aluminum is poured into molds that make them into large blocks of aluminum. The blocks are called ingots.

6 The ingots of aluminum are taken to a can-making factory. There, the aluminum ingots are melted into rolls of flat sheets of aluminum (similar to thick aluminum foil).

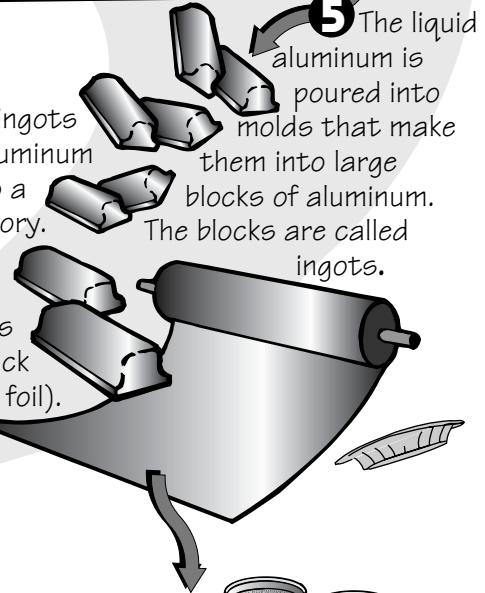

7 Ingots are also sold to manufacturers of aluminum products. These manufacturers melt the ingots down for molding into new products like:

- thumbtacks
- pie pans
- license plate frames
- aluminum foil



The aluminum beverage can returns to the grocer's shelf as a new, filled can in as little as 90 days after being recycled.

8 The sheets of aluminum are cut and shaped into aluminum cans, inspected and shipped to companies that make drinks.

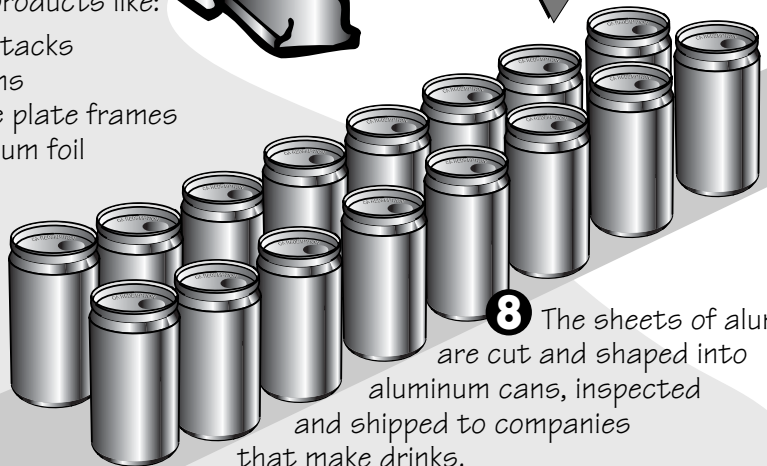

Glass Recycling Process

Have you ever thought about what happens to the glass bottles that you place into your curbside recycle bin or take to the recycling center to be recycled? Recycled glass can be used to make marbles, jars, bottles, plates, bowls, tile and more! This is how:

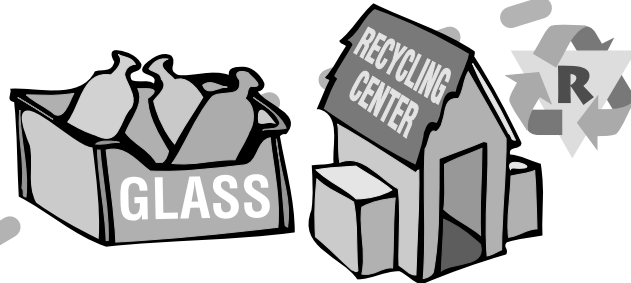

1 The glass bottles collected from your curbside bins are taken to the recycling center.

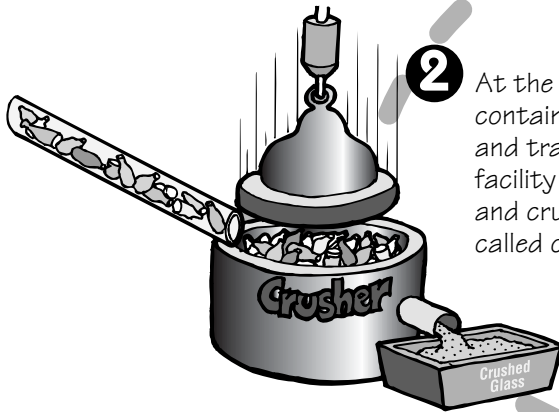

2 At the recycling center, the glass containers are sorted by color and transported to a processing facility where they are cleaned and crushed into tiny pieces called cullet.

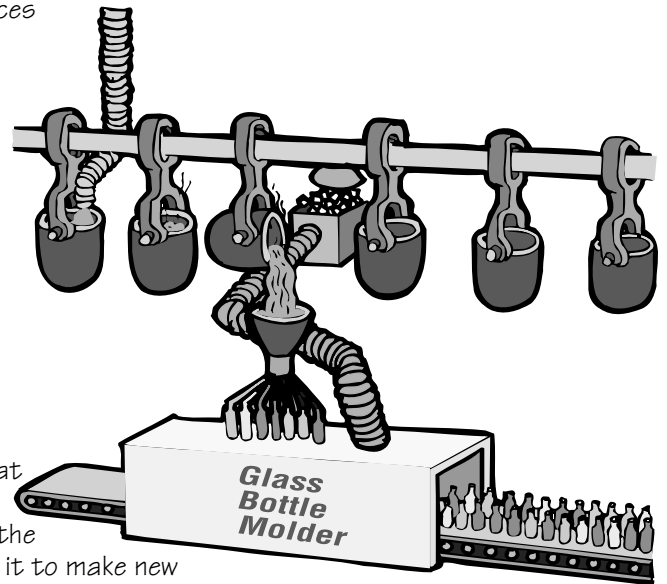

3 Companies that make glass products buy the cullet and use it to make new products.

4 This cycle repeats itself again when we buy the new products, such as glass bottles, and recycle them.



What happens to Recycled Plastic?

1

Plastic containers are brought to the recycling center where they are sorted by type and sometimes color. They are crushed together and formed into a huge cube or bale.



2

The bales of plastic are shipped to a plastics processing plant.



3

The plastic is broken apart and shredded into flakes or pellets and then cleaned.

5

The manufacturer melts the plastic flakes or pellets down for molding into new products like:

- fiberfill for sleeping bags
- plastic lumber
- containers for non-food products
- toys
- compost bins
- rulers
- T-shirts

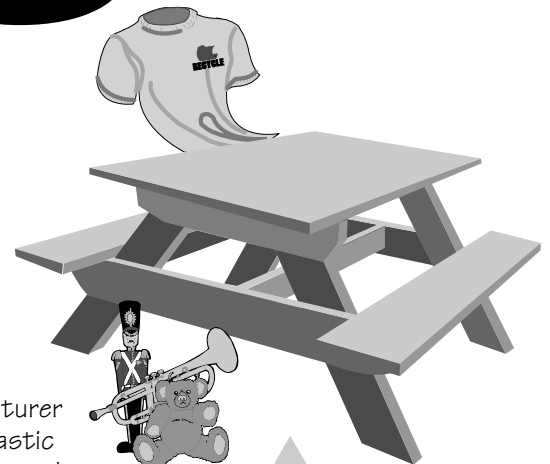

4

The flakes or pellets are shipped to manufacturers of plastic goods.